



# CDVI

  
**santens**  
AUTOMATICS

## BS60 BS60H



***Uninterruptible PSU + Digital Clock Timer option (BS60H)***  
***Alimentation secourue + Option horloge (BS60H)***

**Range:** Power supplies / **Gamme :** Alimentations

INSTALLATION MANUAL  
MANUEL D'INSTALLATION

# BS60 - BS60H

Uninterruptible PSU + Digital Clock Timer Option (BS60H)

## PRODUCT PRESENTATION

- **Regulated PSU.**
- **7 A/H battery included.**
- **Polycarbonate casing.**
- **Primary and secondary inputs protected by fuses.**
- **VO: fire-retardant.**
- **Additional AC output.**
- **Digital clock timer option: BS60H version.**

- Input voltage: 230V ± 10%, 50/60 Hz.
- Power consumption: 0.2A.
- Outputs:
  - 12V dc regulated, uninterruptible,
  - 12V ac non-interruptible.
- Maximum load current:
  - 12V dc output / 1.5A,
  - 12V ac output / 0.5A.

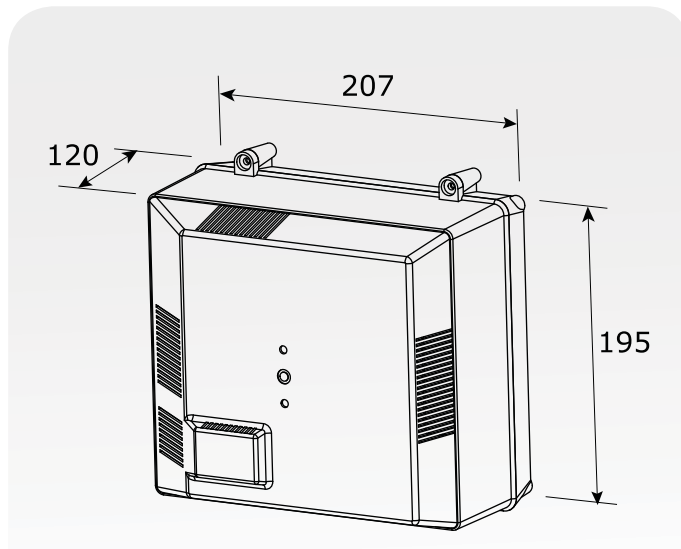

WEEE & RoHS



CE certification



IP30



0°C to +40°C

TERMINAL BLOCK OUTPUTS	VOLTAGE
C	Digital Clock Timer (BS60H only)
R	
T	
+	+12V dc
-	0V
~	12V ac
~	12V ac
1	230V ac
3	230V ac
4 (Black wire)	- Battery
5 (Red wire)	+ Battery

### Assembly and Connections:

Remove the cover by unscrewing the 4 screws at the corners. Thread the wires through the holes designed for this purpose on the lower side. When mounting the casing on a wall, use the screw holes at the corners of the lower part of the casing. **When reassembling do not forget to reconnect the battery wires!**

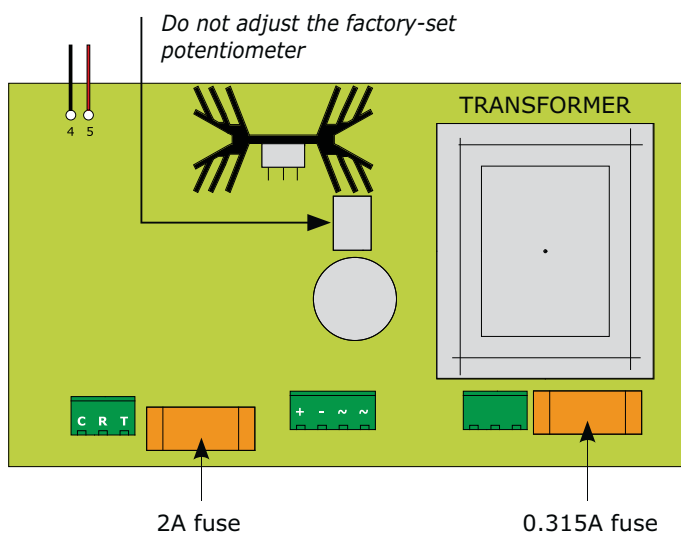

### COMPLIANT WITH EUROPEAN STANDARDS

EN 55022	EN 61000-4-2	EN 61000-4-5
EN 61000-3-2	EN 61000-4-3	EN 61000-4-6
EN 61000-3-3	EN 61000-4-4	EN 61000-4-11

**This product must be installed in accordance with the local safety standards.**

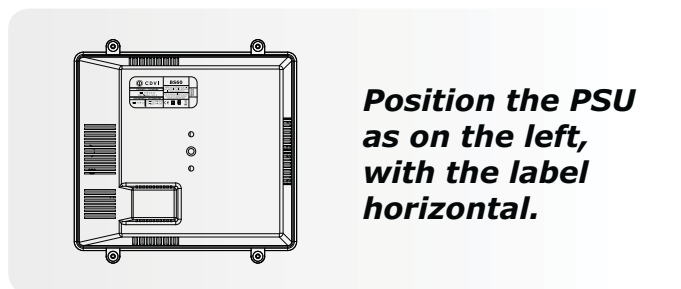

## BS60 - BS60H

Alimentation secourue + Option horloge (BS60H)

### PRESENTATION DU PRODUIT

- **Alimentation régulée.**
- **Batterie 7 A/h incluse.**
- **Boîtier polycarbonate.**
- **Protégée au primaire et au secondaire par fusibles.**
- **VO : ignifugé.**
- **Sorties supplémentaires AC.**
- **Option horloge: version BS60H.**
- Tension d'entrée : 230 V ± 10 %, 50/60 Hz.
- Consommation : 0,2 A.
- Sorties :
  - 12 V DC régulée, secourue.
  - 12 V AC non secourue.
- Intensité maximum :
  - sortie 12 V DC / 1,5 A.
  - sortie 12 V AC / 0,5 A.

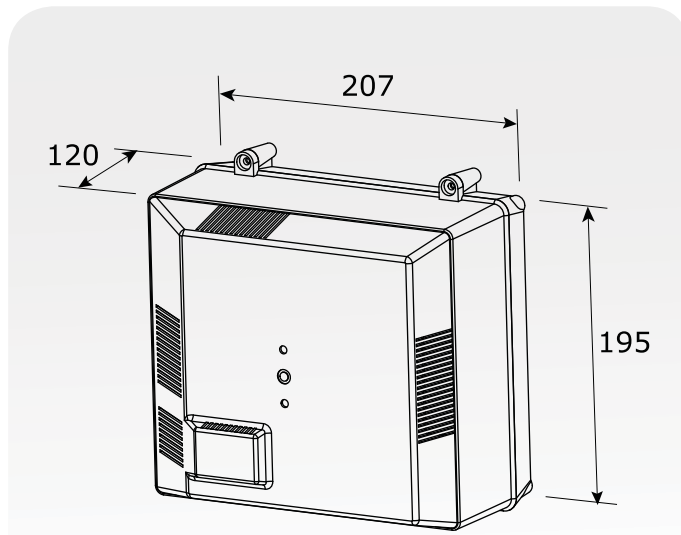

DEEE & RoHS



Certification CE



IP30



0°C à +40°C

SORTIES BORNIERES	TENSION
C	Horloge (BS60H uniquement)
R	
T	
+	+12 V DC
-	0V
~	12 V AC
~	12 V AC
1	230 V AC
3	230 V AC
4 (fil Noir)	- Batterie
5 (fil Rouge)	+ Batterie

#### Montage et Branchements:

Retirer le capot en dévissant les 4 vis situées aux coins. Faire passer les fils par les trous prévus à cet effet, situés sur le côté inférieur. Pour une fixation murale du boîtier, se servir des passages de vis situés au coins de la partie inférieure du boîtier. **Au remontage ne pas oublier de rebrancher les fils de la batterie !**

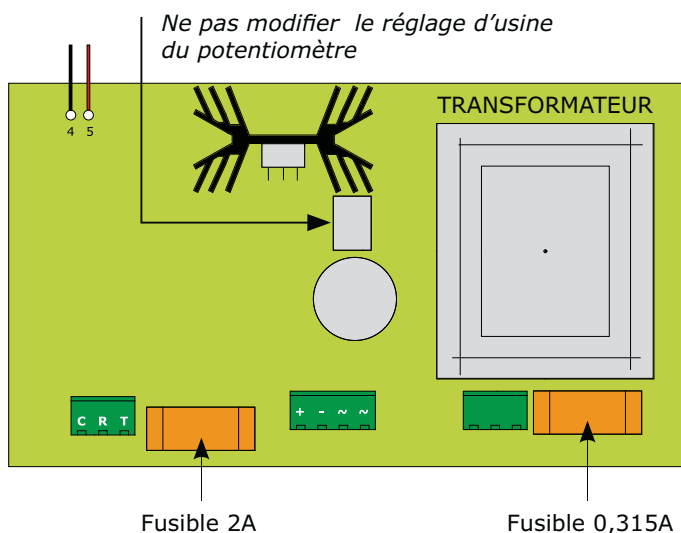

#### CONFORME AUX NORMES EUROPÉENNES

EN 55022	EN 61000-4-2	EN 61000-4-5
EN 61000-3-2	EN 61000-4-3	EN 61000-4-6
EN 61000-3-3	EN 61000-4-4	EN 61000-4-11

**Ce produit doit être installé selon les normes de sécurité électrique en vigueur dans votre pays**

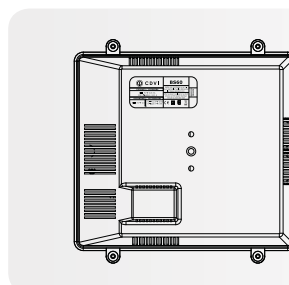

**Positionnement de l'alimentation avec l'étiquette horizontale.**

## Manufacturing Access Control since 1985



All the specifications on this document (photos, drawing, features and dimensions) could be changed without prior notice.  
Toutes les indications mentionnées sur le présent document (photos, dessins, caractéristiques et côtes) sont susceptibles de modifications sans notification préalable.

**CDVI (Headquarters/Siège social)**  
FRANCE  
Phone: +33 (0)1 48 91 01 02  
Fax: +33 (0)1 48 91 21 21

**CDVI**  
AMERICAS  
Phone: +1 (450) 682 7945  
Fax: +1 (450) 682 9590

**CDVI**  
BENELUX  
Phone: +32 (0)5 662 02 50  
Fax: +32 (0)5 662 02 55

**CDVI**  
SWITZERLAND  
Phone: +41 (0)21 882 18 41  
Fax: +41 (0)21 882 18 42

**CDVI**  
CHINA  
Phone: +86 (0)10 87664065  
Fax: +86 (0)10 87664165

**CDVI**  
IBÉRICA  
Phone: +34 935 390 966  
Fax: +34 935 390 970

**CDVI**  
ITALIA  
Phone: +39 0331 97 38 08  
Fax: +39 0331 97 39 70

**CDVI**  
MAROC  
Phone: +212 5 22 48 09 40  
Fax: +212 5 22 48 34 69

**CDVI**  
SWEDEN  
Phone: +46 (0)31 760 19 30  
Fax: +46 (0)31 748 09 30

**CDVI**  
UK  
Phone: +44 (0)1628 531300  
Fax: +44 (0)1628 531003

**DIGIT**  
FRANCE  
Phone: +33 (0)1 41 71 06 85  
Fax: +33 (0)1 41 71 06 86

**LA GÂCHE ÉLECTRIQUE**  
FRANCE  
Phone: +33 (0)3 88 77 32 82  
Fax: +33 (0)3 88 77 85 02